

Name:
Advisor:

Admission Requirements for the Biosystems Engineering Professional School.

Preparatory Courses

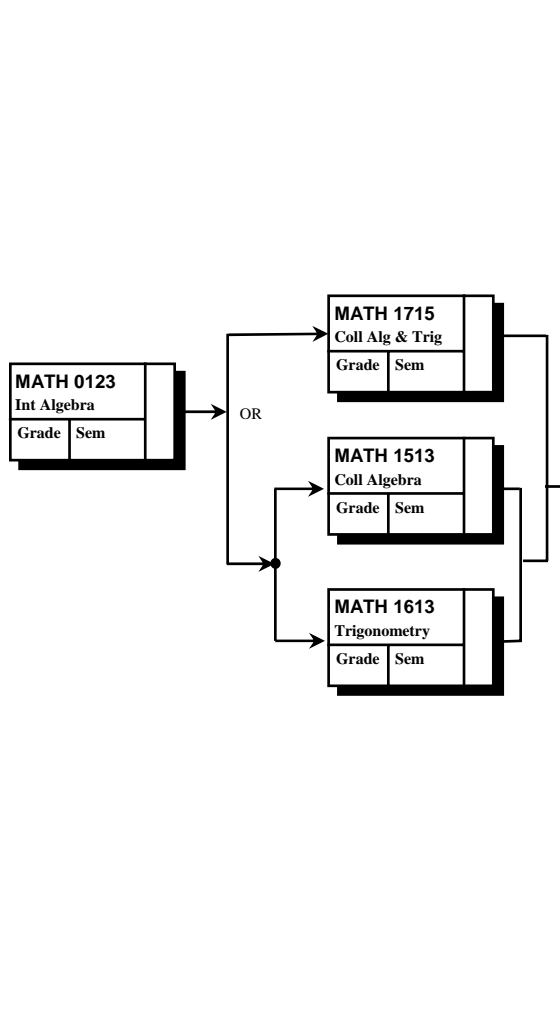

Year 1

Year 2

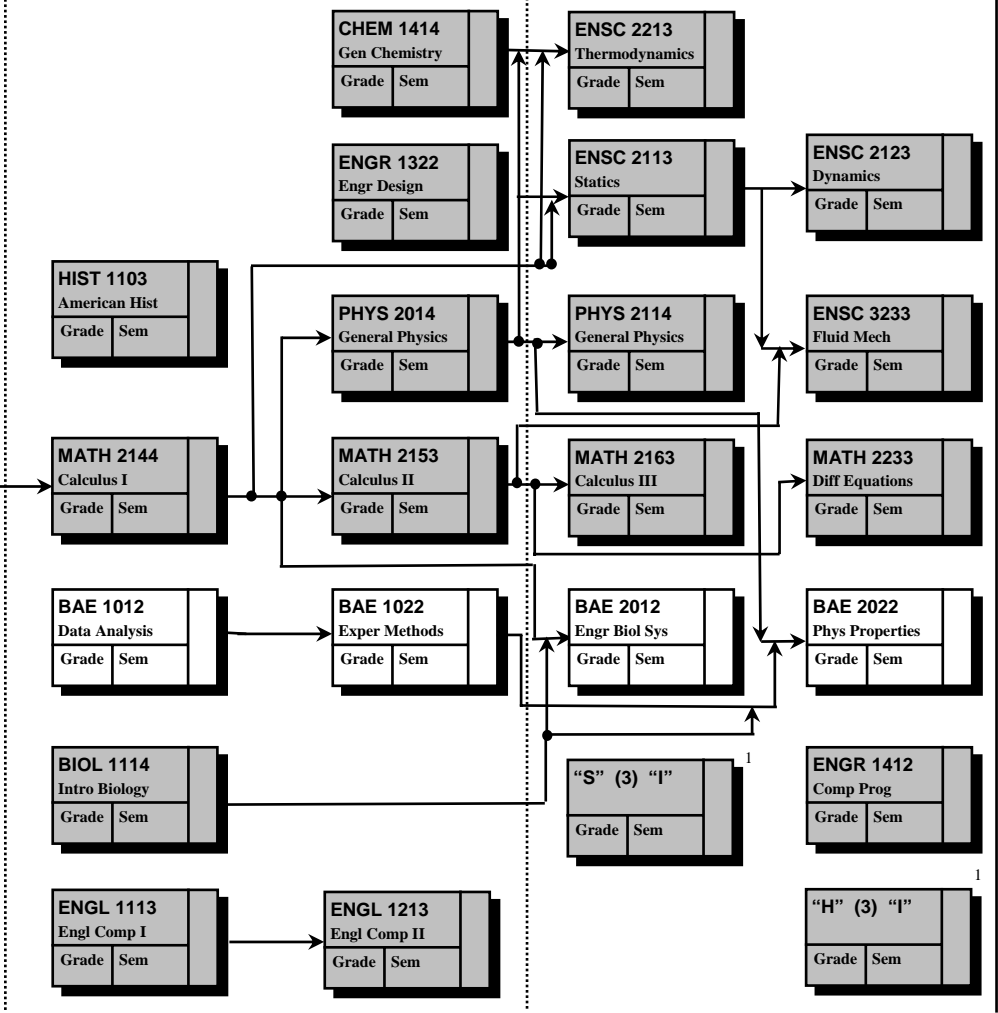

To be admitted into BAE Professional School - to be eligible to take the upper level BAE courses - the student shall have met the Professional School requirements. They are:

- Completion of at least 60 college level semester credit hours (SCH).
- Completion of at least 12 SCH from OSU.
- Completion of MATH 2144, 2153, and 2163; PHYS 2014 and 2114; CHEM 1414; BIOL 1114; ENSC 2113, ENSC 3233, plus two additional ENSC courses; ENGL 1113; BAE 2012 and 2022.
- An overall GPA of 2.3 or better at OSU.
- A GPA of 2.5 or better in all above courses plus any additional math or engineering courses taken at OSU (including STAT, MATH, PHYS, CHEM, ENGR, ENSC, BAE).
- A final grade of "C" or better in each of the above-mentioned courses.

NOTE: This flow chart is for planning purposes only. Students matriculating in 2006 must meet the degree requirements as stated on the official degree requirement sheet dated "Academic Year 2006-2007."

Horizontal arrows indicate prerequisites.

1. At least 6 hours designated "H" and 6 hours designated "S". Of these, 3 hours need to meet the International Dimension "I". Consult the BAE advisor for the BAE General Education Elective Plan form.

Shaded Areas Indicate Common Engineering Curriculum Requirements

Name:

Advisor:

Year 3

Year 4

PREREQUISITES

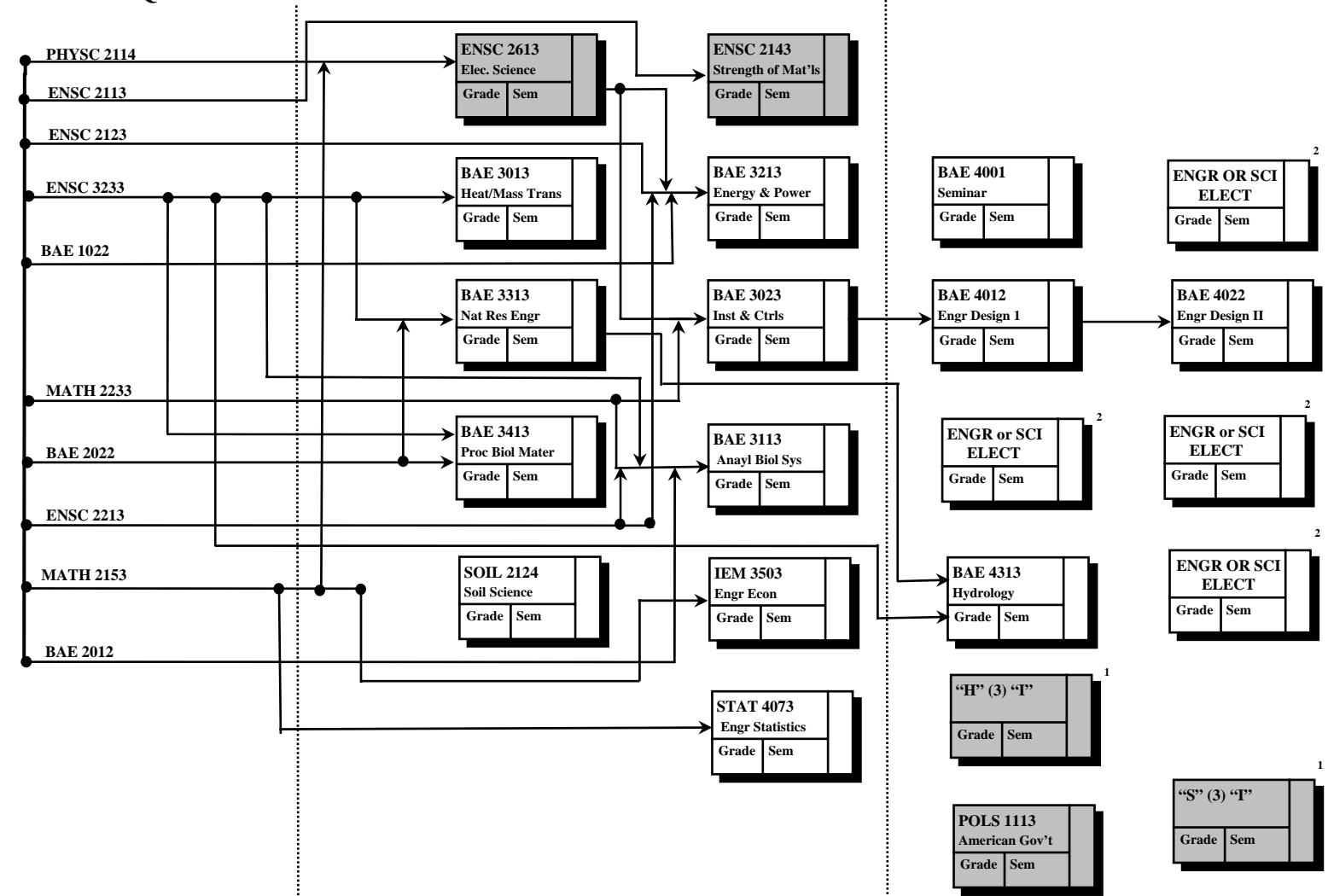

MASTER'S PROGRAMS

Criteria for admission to the Graduate College to pursue the Master of Science include:

1. receive a B.S. degree from an accredited institution.
2. academic performance in undergraduate work at a level that indicates a high probability of success in a graduate program requiring a 3.0/4.0 minimum grade point average.
3. recommended for admission to the Graduate College by a Professional School in the College of Engineering.

For further information, contact the School or the Office of the Dean of Engineering.

A flexible study plan is designed to meet each student's individual goals.

2. 14 hours of courses to be selected from an approved list upon consultation with an advisor, with at least 3 hours from Engineering electives.

* A "C" or better is required in each course that is a prerequisite for a major course.